

The  
GROVE

HANDBOOK OF DESIGN  
STANDARDS

Table of Contents

<b>ARTICLE I – POLICIES AND PROCESS</b>	Page 1
<b>1.1 Authority to Establish Standards and Conduct Design Review</b>	Page 1
<b>1.2 Responsibility For Obtaining Approvals</b>	Page 1
1.2.1 Property Owner is Responsible	Page 1
1.2.2 Property Owner To Comply With Other Laws	Page 1
<b>1.3 Preparation of Submittals</b>	Page 1
1.3.1 Submittals To Be Complete And Accurate	Page 1
1.3.2 Summary of Submittal Requirements	Page 1
1.3.3 Minimum Scale of Drawings	Page 2
1.3.4 Submittals Kept For Record	Page 2
<b>ARTICLE II – INDIVIDUAL LOT DEVELOPMENT STANDARDS</b>	Page 2
<b>2.1 Minimum Required Improvements To Lots</b>	Page 2
2.1.1 Minimum Required Improvements	Page 2
2.1.2 Optional Additional Improvements	Page 2
<b>2.2 Definition of Yards</b>	Page 3
2.2.1 Front Yard	Page 3
2.2.2 Corner Side Yard	Page 3
2.2.3 Side Yard	Page 3
2.2.4 Rear Yard	Page 3
<b>2.3 Locating Structures on a Lot</b>	Page 3
2.3.1 Additions To Houses – Sitting Requirements	Page 3
2.3.2 Accessory Buildings – Sitting Requirements	Page 3
2.3.3 Swimming Pools – Sitting Requirements	Page 3
<b>2.4 Landscaping</b>	Page 4
2.4.1 Minimum Landscaping Requirements	Page 4
2.4.2 Natural Areas	Page 4
2.4.3 Remove All Trash and Debris	Page 4
2.4.4 Trees	Page 4
<b>2.5 Landscape Accessories</b>	Page 4
2.5.1 Mailboxes	Page 4
2.5.2 Flags and Flagpoles	Page 4
2.5.3 Signs	Page 4
2.5.4 Artificial Vegetation, Exterior Sculpture and Similar Items	Page 5
<b>2.6 Pavements</b>	Page 5
2.6.1 Driveways	Page 5
2.6.2 Front Walks	Page 5
<b>2.7 Mechanical, Electrical and Communications Equipment</b>	Page 5
2.7.1 Trash Enclosures	Page 5
2.7.2 Condenser Screening	Page 5
2.7.3 Satellite Antennas	Page 5
2.7.4 Solar Panels	Page 5

<b>2.8 Exterior Lighting and Fixtures</b>	Page 6
2.8.1 Required Post Lamps	Page 6
2.8.2 Other Permitted Fixtures	Page 6
2.8.3 Prohibited Fixtures	Page 6
<b>2.9 Fences</b>	Page 6
2.9.1 Fence Classifications	Page 6
2.9.2 Picket Fences	Page 6
2.9.3 Privacy Fences	Page 7
2.9.4 Prohibited Fence Types	Page 7
<b>2.10 Play Equipment and Structures</b>	Page 7
2.10.1 Definitions	Page 7
2.10.2 Placement and Screening	Page 7
2.10.3 Basketball Goals	Page 8
2.10.4 Play Equipment Construction and Use	Page 8
<b>ARTICLE III ARCHITECTURAL GUIDELINES</b>	Page 8
<b>3.1 Architectural Guidelines – Construction</b>	Page 8
3.1.1 Foundations and Masonry	Page 8
3.1.2 Foundation Vents	Page 8
3.1.3 Fireplaces, Chimneys and Flues	Page 9
3.1.4 Exterior Siding	Page 9
3.1.5 Exterior Trim	Page 9
3.1.6 Windows and Doors	Page 9
3.1.7 Roofs and Roof Accessories	Page 9
3.1.8 Porches and Decks	Page 10
<b>3.2 Architectural Guidelines – Color</b>	Page 10
3.2.1 Types of Approved Finishes	Page 10
3.2.2 Criteria for Judging Color	Page 10
<b>3.3 Additions To Houses</b>	Page 11
3.3.1 Consistency of Design	Page 11
3.3.2 Effects of Design on Privacy of Adjacent Lots	Page 11
<b>3.4 Accessory Buildings (Sheds)</b>	Page 11
3.4.1 Design Limitations	Page 11
3.4.2 Effects of Design on Neighboring Lots	Page 12
<b>3.5 Gazebos</b>	Page 12
3.5.1 Design and Construction	Page 12
3.5.2 Colors and Finishes	Page 12
<b>ARTICLE IV – OTHER STANDARDS</b>	Page 13
<b>4.1 Yard Storage</b>	Page 13
4.1.1 Vehicles	Page 13
4.1.2 Wood Piles	Page 13
4.1.3 Temporary Materials Storage	Page 13
4.1.4 Portable Storage Container & Dumpster Restrictions	Page 13
4.1.5 Water Barrels used for Rain Collection	Page 13

<b>4.2</b>	<b>Holiday Decorations</b>	Page 13
4.2.1	Holiday Decorations	Page 13

<b>APPENDIX A: ILLUSTRATIONS</b>	Page 16
----------------------------------	---------

<b>APPENDIX B: NEIGHBORHOOD ADDENDUM SHEETS</b>	Page 21
---	---------

<b>APPENDIX C: SAMPLE APPLICATION FORM</b>	Page 29
--	---------

**ARTICLE I – POLICIES AND PROCESS**

**1.1 AUTHORITY TO ESTABLISH STANDARDS AND CONDUCT DESIGN REVIEW**

- 1.1.1 The General Covenants establish the authority of the Declarant (Developer) and Association and Association Board of Directors to create design standards and maintain The Grove Architectural Review Board. These Standards have been written not only to establish rules that guide design and construction, but also to define the basis and reasoning for those rules, and to assist the builder and homeowner in understanding the rules by providing illustrations and explanations of requirements where helpful.
- 1.1.2 **AMENDMENTS AND DELETIONS:** The Grove Architectural Review Board reserves the right to modify, add to, or delete from any specific section of The Grove Standards from time to time. All changes must be ratified by the Board of Directors prior to incorporation into these Standards.

**1.2 RESPONSIBILITY FOR OBTAINING APPROVALS**

- 1.2.1 **PROPERTY OWNER IS RESPONSIBLE:** Each property owner within The Grove is responsible for his or her property’s compliance with these Standards. Any proposed improvements to be made to that property may affect that compliance, and the Covenants require that the Owner obtain approvals from the Association prior to making the improvements, in order to maintain compliance. This is true regardless of whether or not the work is being performed by the Owner directly or by a Contractor. Each Owner shall maintain their property at the same level of maintenance as the Homeowners Association maintains the common areas.
- 1.2.2 **PROPERTY OWNER TO COMPLY WITH OTHER LAWS:** In addition to approvals from the Association, other approvals and permits may be required by the County, such as a building permit. It is not the responsibility of the Association, the ARB, or the Developer, to obtain any other permits for you, nor to provide any guarantees or waive any legal requirements for compliance with any state or county law, with the Declaration or with these Standards.

**1.3 PREPARATION OF SUBMITTALS**

- 1.3.1 **SUBMITTALS TO BE COMPLETE AND ACCURATE:** Submittals prepared for consideration by the ARB need to be complete and accurate. Submittals for design review must include drawings prepared as described below. The ARB may require that color chips accompany color applications. All requested information on the application forms needs to be furnished. The ARB will reject applications that are incomplete or inaccurate.
- 1.3.2 **SUMMARY OF SUBMITTAL REQUIREMENTS:** Proper submittals include drawings that are neat, accurate, drawn to scale, and with sufficient detail to adequately explain the entire design. Insufficient explanation of a design including all visible details, is cause for rejection of an application. The ARB, at its discretion, may accept plans that are marked-up in red with late changes to design features. However, the ARB may require that the marked-up sheets be corrected and revised, and resubmitted. As a minimum requirement, one (1) copy of each of the following drawings shall be submitted:

ADDITIONS:

- Site Plan – showing addition location, distances to property lines and tree(s) if any, to be removed. Show any changes in landscaping.
- Floor plan(s) of Addition
- All Exterior Elevations of Addition including existing house. (Show finish materials).

**ACCESSORY STRUCTURES:**

Site Plan – showing location of new structure and existing house, with distances between each, distances to property lines, and tree(s) if any to be removed.

Floor Plan(s)

All Exterior Elevations (Show finish materials).

**OTHER SITE IMPROVEMENTS:**

Site Plan – showing location of improvement, existing structures, distances to property lines tree(s) if any to be removed.

Plan of Improvement (ex: deck, patio, swimming pool, etc.).

**FENCES:**

Site Plan – showing location, extent of fence, and tree(s) if any to be removed. Drawing of fence with heights, materials and sizes identified.

**HOUSE COLORS:**

For changes to existing house colors, submit application form with manufacturer’s names and color names. Submit color chips with application.

**1.3.3 MINIMUM SCALE OF DRAWINGS:**

Site plans shall be drawn to scale (min. 1” = 30’-0).

Drawings of structures, houses, or other improvements shall be drawn to scale (min. 1/8” = 1’-0”).

**1.3.4 SUBMITTALS KEPT FOR RECORD:**

Submittals are kept on file for a record of approved designs.

Therefore, submitted drawings should be copies of originals, not the originals themselves.

**ARTICLE II – INDIVIDUAL LOT DEVELOPMENT STANDARDS**

**2.1 MINIMUM REQUIRED IMPROVEMENTS TO LOTS**

**2.1.1 MINIMUM REQUIRED IMPROVEMENTS:** The following minimum improvements will be required on each developed lot in The Grove:

- **PAVED DRIVEWAY AND FRONT WALK:** All lots developed in The Grove will include a paved driveway and a walk to the front door, in accordance with pavement standards specified in this document.
- **POST LAMP:** All improved lots in The Grove must have a front yard post lamp. The required style is noted in the Neighborhood Addendum.
- **EQUIPMENT AND UTILITIES SCREENING:** Exterior HVAC equipment and Virginia Power Transformers shall be screened in accordance with standards in this document.
- **FINISHED AND LANDSCAPED YARDS:** Every improved lot shall be landscaped in accordance with landscape standards in this document. Consult specific neighborhood addenda as well as general standards.

## **2.2 DEFINITION OF YARDS** (See Illustrations 2.2a and 2.2b in Appendix A)

2.2.1 **FRONT YARD:** The front yard is defined as the lot area between the street and a plane in line with the front façade of the house, extending to both side property lines.

2.2.2 **CORNER SIDE YARD:** On a corner lot, a corner side yard includes all portions of the lot, not a part of the front yard, but fronting on a street and extending to a plan in line with the side façade of the house.

2.2.3 **SIDE YARD:** A side yard is defined as the yard area between the side property line and the house and extending from the front plane of the house to the rear plane of the house.

2.2.4 **REAR YARD:** The rear yard is defined as the yard area extending from the rear plane of the house to the rear property line and to both side property lines except in the case of the corner lots (See Corner Side Yard, above).

## **2.3 LOCATING STRUCTURES ON A LOT**

2.3.1 **ADDITIONS TO HOUSES – SITING REQUIREMENTS** (See also paragraph 3.4 for architectural standards for house additions).

- **YARDS AND SETBACKS:** Additions may be constructed in any yard as defined in 2.2 above but shall not extend beyond the setback limits established for the house.
- **EFFECT ON STREETScape:** Additions in front or corner side yards will be reviewed in relation to their effect on the visual street scape. Additions that significantly impede the view along the street to adjacent homes, beyond that typical of the neighborhood may not be approved.
- **EFFECTS OF LOCATION ON PRIVACY OF ADJACENT LOTS:** In general, the siting of additions shall not create a breach of privacy between neighboring houses. Where this is unavoidable, the ARB may require screening of the view by the Applicant.

2.3.2 **ACCESSORY BUILDINGS – SITING REQUIREMENTS:** (See also paragraph 3.5 for architectural requirements for accessory buildings).

- **LOCATION IN REAR YARD ONLY:** No accessory building may be constructed farther forward on the site than the rear plane of the house.
- **COMPLY WITH SETBACKS:** Accessory buildings shall be located within the minimum setbacks for such structures established by the County except where more restrictive requirements are specified in the *Neighborhood Addenda*.
- **EFFECTS ON LOCATION ON NEIGHBORING LOTS:** In general, the siting of accessory buildings shall not create a breach of privacy between neighboring houses, nor shall it create a visual nuisance to neighboring houses. Where this is unavoidable, the ARB may require screening of the view of the structure by the Applicant.

2.3.3 **SWIMMING POOLS – SITING REQUIREMENTS**

- **LOCATE DIRECTLY BEHIND HOUSE:** In-ground and above ground swimming pools shall be located in the rear yard and no closer than 6' to any property line.
- **PRESERVE PRIVACY:** The ARB may require additional screening of swimming pools to insure the privacy of the pool's owner and of neighbors.
- **FENCING REQUIRED:** Swimming pools shall be fenced in accordance with State building codes and in conformance with Article II, Section 2.10 "Fences".

## 2.4 LANDSCAPING

- 2.4.1 **MINIMUM LANDSCAPING REQUIREMENTS:** All homes shall have foundation plantings located along the front façade at a minimum. All cleared yard areas not otherwise specified in accordance with any *Neighborhood Addendum*, shall be landscaped with a combination of seeded or sodded lawns, planting beds for shrubs, trees, ground cover or flowers with mulch or otherwise landscaped in accordance with an approved landscape plan.
- 2.4.2 **NATURAL AREAS:** Areas of yards which contain mature natural vegetation and are permitted to be left in a natural state should be maintained free of dead and diseased trees.
- 2.4.3 **REMOVE ALL TRASH AND DEBRIS:** No new landscaping shall commence until all trash, stones, gravel, branches weeds and construction debris have been removed from the lot.
- 2.4.4 **TREES:** To the extent reasonably practical, the clearing of mature trees on Lots shall be limited. No trees measuring six (6) inches in diameter shall be removed without prior written approval of the ARB. If the tree removed is located in the front yard, the ARB must be informed if it is to be replaced and with what type of tree. If removed tree(s) will not be replaced, then the stump and mulch must be removed, and seed or sod should be used as a ground cover. Stumps of trees in rear yards that will not be replaced may be flush cut or removed entirely.

## 2.5 LANDSCAPE ACCESSORIES

- 2.5.1 **MAILBOXES:** (*See Illustration 2.5.1 in Appendix A*). Mailboxes must be installed utilizing the standard The Grove post and the approved size box. Boxes shall be metal with a gloss Dark Hunter Green finish. Specified wood posts shall be painted with gloss white paint. Numbers shall be raised and painted gloss Dark Hunter Green to match box. Mailbox post and the paper box may be white vinyl PVC. Grove post dimensions 5 to 6 feet tall, 4 inches wide. Sides of paper box are  $\frac{3}{4}$  thick, 7  $\frac{1}{4}$  inches from top to bottom, top of the side is 23 inches long and the bottom is 21 inches long.
- 2.5.2 **FLAGS AND FLAGPOLES**
- **FLAGS MOUNTED ON HOUSES OR GARDEN STAKES:** Decorative flags and sovereign flags (USA, Virginia, Chesterfield County) are permitted to be flown from flag standards of 6' or less in length, mounted on house. Flag styles limited to seasonal, holiday, sports, military and schools. Flags cannot depict or contain any political message. Lot owners are permitted a maximum of three garden flags to be displayed in their yard. Each flag shall not exceed the maximum size of 14" wide by 20" tall and shall be placed no higher than 36" above the ground.
  - **VERTICAL FLAGPOLES:** Permanent vertical flagpoles are not permitted in front yards. Flagpoles not exceeding 15' in height may be permitted in rear yards directly behind the house and no closer than 20' to any property line.
- 2.5.3 **SIGNS**
- **PERMITTED SIGNS:** One alarm company sign per lot is permitted. No signs other than one temporary real estate sign. Open House directional signs may be placed only on weekends but must be removed within 3 hours of completion of Open House.
  - **REAL ESTATE SIGNS:** Real estate signs shall be placed in the front center of the yard only. Rear or side yard signs are not permitted. Sign should not be more than (2) square feet or as regulated and permitted by the County Code advertising the property for sale. Will permit a maximum of 3 square feet.



2.5.4 **ARTIFICIAL VEGETATION, EXTERIOR SCULPTURE AND SIMILAR ITEMS:** No artificial vegetation shall be permitted on the exterior of any Lot. No exterior sculpture, fountains, bird houses, bird baths or other decorative embellishments of other similar items shall be permitted in the front yard unless approved by the ARB. They may be located in the back yard as long as the quantity is reasonable.

## **2.6 PAVEMENTS**

2.6.1 **DRIVEWAYS:** Every improved lot in the Grove shall have a single paved driveway that conforms to the following criteria (See also Neighborhood Addenda for any special requirements).

- **PAVEMENT:** Driveways must be hard surfaced using asphalt or concrete. Gravel is not permitted. Upgraded pavements may include brick pavers, exposed aggregate concrete, interlocking concrete pavers or patterned concrete.
- **SETBACKS:** Driveways shall be held a minimum of 3' off of side property lines.

2.6.2 **FRONT WALKS:** All front walks shall be hard surfaced. Upgraded walks will generally be permitted of brick, exposed aggregate concrete, concrete pavers, embossed concrete or stone cut (mortar set). Walks shall be between 3' and 4' in width, widening as required to the front step's width.

## **2.7 TRASH, MECHANICAL, ELECTRICAL AND COMMUNICATIONS EQUIPMENT**

2.7.1 **TRASH ENCLOSURES:** Trash, garbage and other waste shall be kept in sanitary containers located and screened so as to be concealed from view of the neighboring lots and the Street. A screening enclosure for trash is required on all lots and shall be built to match the condenser screening enclosure (see below). It shall be located at the back side or rear of the house to screen the container from the street and neighboring lots. It must be the same height as the sanitary container. *(Amended 2/01)*

2.7.2 **CONDENSER SCREENING:** Required screening of heat pump or air conditioning condensers may be by finished or unfinished (salt-treated) vertical board fence enclosures or lattice enclosures, properly supported, trimmed, level and plumb. Equipment shall be screened on all sides with allowances for one 3' wide opening not visible from the street. Spaced between vertical boards shall be 2" max. The height of the screening enclosure shall be at least as high as the equipment screened, but not more than 1' higher.

2.7.3 **SATELLITE ANTENNAS:** No longer restricted.

### **2.7.4 SOLAR PANELS**

- An Architectural Modification Request Form must be completed and submitted to the ARB in advance for any addition of solar energy collection devices.
- Written approval from the ARB is required in advance.
- Only commercially manufactured solar energy collection devices are permitted. Solar energy devices, whether water heating or electrical generating, are allowed to be installed on the roof of a house or other approved structure; they may not be installed in common areas..
- A complete description (photos/drawings) as to the construction design, materials (types and sizes), proposed location and color/finish must be provided to the ARB in advance.
- The unit owner acknowledges that they are responsible for any liability, damage, repair, etc., caused or created by the installation of the solar collection device. The Association is not liable for any liability, damage or repair related to the installation, placement or maintenance of the solar collection device. If a device is not properly maintained, the Association will require the removal of the device.
- The unit owner is responsible for getting all approvals and inspections from the county and providing such documentation to the ARC prior to commencing any construction of the project.

## 2.8 EXTERIOR LIGHTING AND FIXTURES

2.8.1 **REQUIRED POST LAMPS:** A standard post lamp is required in each neighborhood. The post shall be 5'-7' long, 3" diameter black aluminum with a traditional ladder rest (crosspiece), if required by individual neighborhoods. Lamp fixtures for most neighborhoods (were) manufactured by Progress Lighting. The lamp fixture for Hawkins Woods (was) manufactured by Kichler Lighting Company; (however, post lamps may be replaced with a similar fixture following ARC approval.) Neighborhood Addendum Sheets: Biggin Pond, Gravity Hill, Hawkins Woods, Krim Point, Mitford, Kingham and Coalbrook: Required post lamp style: ADD: A fixture to match as closely as possible to the original requirements.

### 2.8.2 OTHER PERMITTED FIXTURES

- **GENERAL TYPES PERMITTED:** Other exterior light fixtures shall be limited to lights at entrances, at garage door, low intensity landscape or driveway lights and side or rear (only) eave mounted floodlights directed completely within the applicant's lot area.
- **FAÇADE FLOODLIGHTING:** Floodlighting of front facades will be permitted by the ARB on condition that floodlights and the fixtures are concealed in landscape beds.

2.8.3 **PROHIBITED FIXTURES:** High intensity house or pole mounted area or security lights are prohibited. "High intensity" refers to ballasted light fixtures using high- or low-pressure sodium, mercury vapor or metal halide lamps.

## 2.9 FENCES

### 2.9.1 FENCE CLASSIFICATIONS

There are two classifications of fences that may be used in The Grove: picket fences and privacy fences. Each classification has different requirements and limitations which are defined below. Applicants for fence approval should review each classification and determine what type of fence they wish to erect, then apply under the appropriate classification. Where a new fence will abut an existing fence, the new fence will be similar in style to the existing fence unless the homeowner can make a compelling case for a different style.

### 2.9.2 PICKET FENCES (*See Illustration 2.9.2 in Appendix A*)

- **DEFINITION:** Picket fences are defined as any open picket fence. Fences may be constructed of finished or unfinished treated wood or naturally decay resistant wood, white vinyl PVC or black wrought iron. All fences shall be constructed of dimensional lumber, not rough split wood. Simple square posts are permitted. Pickets shall face the outside of the lot.
- **LOCATION AND USE:** Picket fences shall be permitted in rear yards only and shall not extend any farther forward than the rear plane of the house. Front yard fencing is not permitted. *Except as noted below*, the fence may extend up to any property line that abuts another lot or directly up to any property line that abuts common area or property not in The Grove. Rear yard fences may extend into corner side yards up to 15' from the corner side property line. *Exception: Exceptions to forward of the rear plane may be made on a case-by-case basis by the ARB. Where rear yards narrow to a point (no rear lot line) or to a very short rear lot line, the ARB may require that the rear fence line be set in from the rear lot line or point at a reasonable distance to avoid very narrow fenced yards.*
- **HEIGHTS:** Picket fences are limited to 48" in height from the ground to the top rail or to the top of the pickets. Privacy fences are limited to a maximum height of 84" to the top of the fence.

- **ADJOINING FENCES:** Where a fence has been constructed on an adjoining lot up to a side or rear property line that abuts your lot, you may construct an approved fence of the same or different design on your lot that meets (abuts) the adjoining fence. You may not construct your own fence on the property line that has already been fenced by a neighbor.

2.9.3 **PRIVACY FENCES:** *(See Illustration 2.9.3 in Appendix A)*

- **DEFINITION:** Privacy fences shall include any solid board or lattice fence. Fences may be constructed of finished or unfinished treated wood or naturally decay resistant wood or white vinyl PVC. Simple square posts are permitted. Boards or lattice shall face the outside of the lot.
- **LOCATION AND USE:** Privacy fences shall be limited to an area directly behind the rear plane of the house.
- Privacy fences are limited to a maximum height of 84” to the top of the fence.

2.9.4 **PROHIBITED FENCE TYPES:** The following fence types are prohibited for use in any area of The Grove: board rail, split rail, turned rail or any other rough cut rail fences, chain link fences, barbed wire fences, horizontal board fences, stockade style solid picket fences and post and wire fences. Any fence type not described in this article, shall be submitted for review by the ARB to determine if it may be used and under which classification.

**2.10 PLAY EQUIPMENT AND STRUCTURES**

2.10.1 **DEFINITIONS**

- **PLAY EQUIPMENT:** Play equipment are often highly visible and depending on their design and application, they may defeat many of the aesthetic and environmental goals that the community has sought to achieve. For this reason, the Association requires approval of all exterior play equipment prior to placement on the lot. For the purposes of this article, play structures and equipment shall include but not be limited to the following:  
 SWING SETS  
 SLIDING BOARDS  
 JUNGLE GYMS – CLIMBING STRUCTURES  
 BASKETBALL GOALS  
 TRAMPOLINES
- **ENCLOSED STRUCTURES:** Forts, Treehouses, Playhouses or other enclosed play buildings with an interior height of 6’-0” or less floor-to-ceiling, and with a total floor area of less than 36 square feet shall be considered to be Play Structures. Dog houses area also permitted under this section. Larger buildings are considered to be Accessory Buildings regulated under Article III, Section 3.6 of these Standards.

2.10.2 **PLACEMENT AND SCREENING**

- **PLACEMENT:** Play Equipment shall be located in rear yards only, away from property lines adjacent to other houses or streets and away from neighbor’s direct view where possible.
- **SCREENING:** The ARB may require that certain play equipment be screened from view. The standard requirement for screening will be to provide densely shaped evergreen shrubs or trees of a heigh when planted of at least 2/3 the height of the structure, and so placed as to provide a continuous screen on the stipulated side. Planting can be in a continuous row or staggered. A variety of shrubs/trees may be used in addition to single species solutions. It shall be the responsibility of the homeowner to submit to the Board a plan and proposed plant types for review. Privacy fences may also be proposed by the homeowner for construction as screening.

### 2.10.3 BASKETBALL GOALS

Basketball goals may be installed adjacent to driveways in accordance with the following criteria:

#### a) PERMANENT BASKETBALL EQUIPMENT

1. The mounting pole is to be metal and to be painted black, brown or painted a neutral earth tone.
2. The backboard must be grey, white, or clear acrylic. Specifically, colored backboards are not permitted.
3. The structure may not directly face the street unless otherwise approved by the ARB. Basketball goals may be mounted on the side or rear face of garages, except when such location faces a street, or on a pole mounted on the side of the driveway facing the house and no farther forward than the front corner of the house. Basketball goals may not be placed in the street or at the end of the driveway.
4. The addition of paving material for a playing court also requires review and approval and may require County approval.
5. Due to the proximity of units in attached housing, the permanent installation of basketball equipment is not permitted for placement in the community setting.

#### b) PORTABLE BASKETBALL EQUIPMENT

1. The hoop must be maintained a minimum of fifteen (15) feet from the street located on or adjacent to the driveway.
2. No more than one piece of basketball equipment to include the hoop, net and pole will be permitted on any property.
3. The hoop is located so that basketballs will not fall into the yards of adjoining homes.
4. The configuration of the driveway, distance from the street and proximity of adjoining lots must accommodate these guidelines.
5. Portable basketball goal/hoops systems must be stabilized by filling the base with water or sand according to manufacturer's instructions. No other form of weighting, for example: cinder blocks, bricks, bagged sand, mulch or gravel is acceptable. If the hoop cannot be stabilized following the manufacturer's instructions, it is not suitable for placement in the community setting.

Basketball hoops, poles, mounting and nets must be maintained. Faded, rusted, and/or unsightly basketball hoops must be repaired, removed, or replaced. Frayed or torn nets must be replaced

### 2.10.4 PLAY EQUIPMENT CONSTRUCTION AND USE

Factory built; pre-finished equipment is preferred but not required. Home-built play equipment should be neat and orderly in appearance and finish.

Homeowners should exercise care and common courtesy in using play equipment that creates noise (i.e. basketball goals).

Play equipment which has fallen into disrepair or has been outgrown by children should be removed from the property.

## ARTICLE III – ARCHITECTURAL GUIDELINES

### 3.1 ARCHITECTURAL GUIDELINES – CONSTRUCTION

3.1.1 FOUNDATIONS AND MASONRY: All visible portions of exterior foundations shall be constructed of brick or stone. Four houses with primary facades constructed entirely of brick, the foundation brick shall match the brick façade. Synthetic stucco foundations may be permitted for facades entirely constructed of synthetic stucco.

3.1.2 FOUNDATION VENTS: Consult *Neighborhood Addendum* for special requirements for foundation vents in each neighborhood. If no special requirements are stated, standard metal foundations vents are permitted.

### 3.1.3 FIREPLACES, CHIMNEYS AND FLUES

- **PERMITTED CHIMNEY TYPES:** All chimneys shall have foundations of materials that match the house foundation. Cantilevered frame chimneys are not permitted.
- **METAL FLUE REQUIREMENTS:** Unenclosed metal flues shall not be visible from the front of the house unless painted to match the color of roofing material.
- **DIRECT VENT FIREPLACES:** For direct vent gas fireplace boxes which protrude beyond the exterior plane of the house, the frame structure must have a foundation to match the house foundation, and all exterior materials and finishes used to enclose the fireplace box must match the adjacent façade.

### 3.1.4 EXTERIOR SIDING: Facades shall be faced with one or more of the following materials: brick, stone, synthetic stucco or approved horizontal lap siding.

- **APPROVED HORIZONTAL LAP SIDING:** Horizontal lap siding may be. Manufactured from natural wood, hardboard or pre-finished vinyl (see below).
- **CRITERIA FOR VINYL SIDING:** The submitted product must be the manufacturer's premium grade vinyl product as evidenced by manufacturer's printed literature in order to be considered by the ARB for approval. Minimum product thickness shall be .044".
- **OTHER MATERIALS:** Materials other than those listed above will be considered on a case-by-case basis by the ARB.
- **COMPATIBILITY OF MATERIALS:** Where siding materials are used in combination, they shall be aesthetically compatible with each other as determined by the ARB.

### 3.1.5 EXTERIOR TRIM: Exterior architectural detailing shall be consistent with the overall design theme of the house, Eaves, band boards, cornices, rakes, columns, pilasters, corner boards, vents, window and door trip shall be consistent with the style of the house and sized appropriately to the scale of the house. The ARB reserves the right to require modifications to the façade to accommodate appropriate trim.

### 3.1.6 WINDOWS AND DOORS

- **STORM DOORS:** Storm doors shall be compatible with the units that they cover and with the style and color of the house. Excess ornamentation not consistent with other ornamentation of the house, is prohibited. In general, single full lite doors or traditional multiple lite doors which match the design characteristics of the doors they cover will be approved.
- **WINDOW AIR CONDITIONERS:** Window and through-wall air conditioning units are prohibited on primary (street facing or street visible) elevations.
- **AWNINGS AND TRELLISES:** Sun control devices such as awnings and trellises must be compatible with the architectural style, character and color of the house. The ARB reserves the right to prohibit the use of such devices on the front of any home.
- **SHUTTERS:** Shutters should be compatible with the style, materials and colors of the house and should be of proper proportions to the windows they adjoin.
- **GARAGE DOORS:** Garage door detailing shall be consistent with the architectural style of the house. Metal garage doors shall approximate the appearance of wood garage doors. The ARB may reject doors that do not adequately meet this standard.
- **BAY WINDOWS:** Bay windows are permitted on all facades, either cantilevered or with a foundation.
- Windows must be wide enough to fill each bay façade without filling with siding.
- Siding may be used under windows, with a band board and drip cap at the base of the siding.

### 3.1.7 ROOF AND ROOF ACCESSORIES

- **ROOF MATERIALS:** Approved roofing materials vary by neighborhood. Other materials will be judged on their own merits but are subject to disapproval by the ARB. See the Neighborhood Addendum to determine the specific roofing materials permitted for each neighborhood. In general, only one material may be used on all roofs on the same house, except that porch roofs may be of a different material than the main roof.

- **SHINGLE COLORS:** Composition shingle colors are recommended to be in the medium to deep brown or grey ranges. Very light colors and black or white shingles will not be approved.
- **GUTTERS AND DOWNSPOUTS:** Gutters and downspouts shall be pre-finished to match the adjacent building material color. Downspouts shall include short turnouts at their outlets. If extensions are required, they shall utilize corrugated pipe below grade.
- **FLASHING:** Highly visible roof flashing shall be copper or pre-finished to match the adjacent building material color. Painting is acceptable for less visible flashing, however no exposed mill finished flashing is permitted. Imitation copper will not be permitted.
- **ROOF VENTS:** Attic ventilators and other roof penetrations shall be low profile designs.
- **ROOF DORMERS:** Dormer windows and eyebrow windows are permitted as consistent with the style of the house.
- **SKYLIGHTS:** Skylights will not be approved for the front roof planes of houses. Where skylights are permitted, they shall be trimmed in pre-finished metal similar to the roof color.

### 3.1.8 PORCHES AND DECKS

- **FRONT PORCH CONSTRUCTION:** All front entry stoops and extended front porches shall be constructed of finished materials to match the house. Band boards, handrails and railings shall be painted wood or metal railing of a design to match the character and style of the house. Columns supporting roofs on porches and covered stoops on primary facades, shall be finished columns or square posts appropriate to the character of the house. Colonial turned posts and solid square posts are permitted. All front porches must be built on solid foundations or brick piers with lattice required regardless of height. Steps shall have closed risers.
- **REAR DECK CONSTRUCTION:** Rear patio decks shall be constructed of quality exterior grade or pressure treated wood, including steps with closed risers and railings. Grade level patios and terraces are encouraged. The space beneath all decks higher than 2' above grade but less than one story above grade shall be enclosed with lattice or other approved screening material.
- **DECK FINISH:** Decks constructed at or below the first-floor level of a house may be constructed entirely of unfinished treated lumber, however staining or painting of decks is acceptable. Decks or balconies constructed above the first-floor level shall be finished to match the house except for deck flooring which may be unfinished.
- **SECONDARY PORCHES:** On secondary facades, open porches, stoops and screened porches shall all be constructed of materials to match the house, except for deck flooring.
- **SPAS:** Spas and hot tubs are permitted on attached rear decks. Remote decks for spas and hot tubs, or free-standing units must be located behind the house so as not to be visible from the street, and no closer than 10' to any property line.

## 3.2 ARCHITECTURAL GUIDELINES – COLOR

### 3.2.1 TYPES OF APPROVED FINISHES

- All exterior colors must be approved by the ARB prior to painting or the application of pre-finished materials.
- Painted siding shall be painted with an oil or latex based exterior house paint. Semi-transparent stains and clear finishes are not permitted.
- Vinyl siding shall be pre-finished with an integral color as approved and shall not be painted.

### 3.2.2 CRITERIA FOR JUDGING COLOR

- The same or very similar color schemes may not be used on adjacent houses nor on houses directly across from each other. The ARB may also reject a proposed siding color if it determines that the color has been used on too many houses in the same neighborhood.

- Color selections are not limited to a restricted list; however, colors should generally be muted in hue, especially for large areas such as siding. Stronger colors may be approved for focal points such as doors and shutters. Colors selected must be harmonious with each other and with other finishes such as masonry foundations and roof colors. Shingle and metal roof colors shall be submitted at the same time as house colors. Provide a sample or color chip for approval.
- Additions and accessory buildings must be finished in the same colors as the house.

### **3.3 ADDITIONS TO HOUSES**

- 3.3.1 **CONSISTENCY OF DESIGN:** To ensure consistency in the design of the house and minimize visual disruption of the neighborhood, additions must match the design characteristics of the house. Specifically:
- The architectural style shall match the style of the house. The massing of the addition shall be similar in the use of shapes to that of the house but proportionately smaller so to not overpower the house. Roof styles and slopes shall be similar.
  - Openings shall be required in additions, including windows and doors, in a similar fashion and extent (min.) as in the original house. Windows and doors shall be of matching material as those in the. House. In general, windows and doors should match the style of those in the existing house. Exceptions may be granted at the discretion of the ARB for sunrooms or other specially glazed areas.
  - Architectural elements such as corner and rake boards, soffits, eaves, window and door trim, and shutters shall match the style of the same elements on the house.
  - All exterior finish materials and colors shall match the house. Matching colors on dissimilar materials is not acceptable.
  - The space beneath any structure constructed on piers (including decks) higher than 2' above grade but less than one store above grade shall be enclosed with lattice or other approved screening material.
  - Solarium additions shall be constructed of finished wood framing or of a pre-finished metal consistent with the house exterior color scheme.
- 3.3.2 **EFFECTS OF DESIGN ON PRIVACY OF ADJACENT LOTS:** New windows or access created by the addition or modification should not create a breach of privacy between neighboring houses. The ARB reserves the right to reject certain openings or require screening by the applicant in situations where, in the opinion of the ARB, it is required.

### **3.4 ACCESSORY BUILDINGS (SHEDS)**

- 3.4.1 **DESIGN LIMITATIONS:** Sheds shall match adjacent houses (at a minimum) or may be specially designed in a unique style, to the extent that it enhances the overall design of the house and lot in the opinion of the ARB. Economy kit sheds from home improvement stores are not permitted unless they fully comply with the minimum requirements outlined as follows. Except for special designs, minimum requirements include:
- The architectural style shall match the style of the house. Roof styles and slopes shall be similar, i.e., gable roof shed with gable room house, etc. Shed roofs shall be constructed at a minimum 8:12 or 8 ½ pitch.
  - Windows and doors in accessory building shall be similar in style to those in the house. Alternate styles of shed doors may be approved at the discretion of the ARB.
  - All exterior finish materials and colors shall match the house. Matching colors on dissimilar materials is not acceptable.
  - Accessory buildings may be set on foundations which match the house or may be set directly on the ground on skids. When skids are used, the shed should be set level and plumb. Any space visible under the shed must be concealed with lattice or plantings. The ARB may require that certain accessory buildings be screened from view. The standard requirement for screening will be to provide densely shaped evergreen shrubs or trees of a

height when planted of at least 3 or 4 feet, and so placed as to provide a continuous screen on the stipulated side(s). Plantings can be in a continuous row or staggered. A variety of shrubs or trees may be used in addition to single species solutions. It shall be the responsibility of the homeowner to submit to the Board a plan and proposed plant types for review.

- The maximum floor area of any shed shall be 160 square feet (ex: 10' x 16'), unless otherwise approved by the ARB. Exceptions to this limit will be judged on the basis of exceptional design merit and building location that does not significantly impact adjacent properties or the visual landscape.
- The maximum interior height of a shed shall be 8', measured at the eaves (exclusive of sloped roof height).
- No detached garages will be permitted on any lot.

3.4.2 EFFECTS OF DESIGN ON NEIGHBORING LOTS: New windows or access created by the accessory building shall not create a breach of privacy between neighboring houses. The ARB reserves the right to reject certain openings or require screening by the applicant in situations where, in the opinion of the ARB it is required.

### 3.5 GAZEBOS

#### 3.5.1 DESIGN AND CONSTRUCTION

Acceptable gazebos shall generally be octagonal (8) sided structures consisting of a base deck, decorative columns or posts, optional railings and a sloped roof. Stepped roofs and/or cupolas may be added. Structures of other shapes such as square structures will be considered on the basis of equal architectural merit. Additional standards include:

- The maximum width of a gazebo across flat sides shall be 14'-0". The maximum height from gazebo deck to eave edge shall be 8'-0". Gazebos shall have roof slopes generally of at least 8:12 or 8 1/2. Slopes shall be appropriate to size and style of gazebo.
- Gazebos shall be constructed of weather resistant wood, preferably western red cedar, cypress or redwood, although pressure treated southern yellow pine will be the acceptable minimum. All exposed wood members, except decking, shall be surfaced (finished smooth) on all exposed sides. Posts, railings and other open wood members shall be turned, edged or worked into shapes consistent with traditional gazebo designs. Unfinished, dimensional lumber will not be approved for exposed open or free-standing members.
- Additional trim, detailing, brackets, cupolas, etc. shall be appropriate to the design and size of the gazebo. The ARB reserves the right to deny gazebo designs with excessive and inappropriate detail, as well as with insufficient detail.
- Gazebos may be built on site or assembled from kits. Applications for approval must include either scale drawings of plans and elevations or manufacturer's brochure showing the exact gazebo being purchased, with dimensions and specifications.

#### 3.5.2 COLORS AND FINISHES

Gazebos constructed on decks attached to the primary house shall be painted to match the trim color of the house and roofed with shingles that match the house shingles. Free-standing gazebos set away from the house may be painted to match the house trim or finished with a clear finish. Roofing shall match the house or be cedar shake.



## **ARTICLE IV – OTHER STANDARDS**

### **4.1 YARD STORAGE**

- 4.1.1 **VEHICLES:** The following vehicles may not be parked or stored on any lot (except in an approved garage), common area or street in The Grove: campers, house trailers, horse and utility trailers, recreational vehicles, boats, motorcycles, school buses or commercial vehicles over 6,000 lbs. net vehicle weight, or with dual wheels, inoperable vehicles, vehicles without current registration, or similar items. These vehicles must be parked in an area designated by the Association, or if no such area is designated, they must be parked outside the development. Major vehicle repairs may not be undertaken except in enclosed garages. Minor emergency repairs such as battery charging or changing, replacing a flat tire, and jump starting are permitted in the open on any lot. Four wheelers, dirt bikes and other recreational motorized vehicles are not permitted on the Grove HOA common areas. All operators must respect and abide by Chesterfield County Codes and Ordinances in regard to unnecessary noise, age requirements and operation of said motor vehicles in The Grove.
- 4.1.2 **WOOD PILES:** Firewood may be stored on lots in the rear yard only and no closer than 10' from any side property line. The ARB will consider the design and location of covered structures for wood piles. Fabric tarpaulins may not be used for continuous cover of wood piles.
- 4.1.3 **TEMPORARY MATERIALS STORAGE:** Temporary storage of construction, yard work or landscape materials is permitted in the rear yard only. Material may be covered with natural (green, tan or brown) colored tarpaulins. Bright colored tarpaulins are not permitted.
- 4.1.4 **PORTABLE STORAGE CONTAINER AND DUMPSTER RESTRICTIONS:** Portable temporary storage units (such as containers provided by PODS, Smart Boxes or similar moving and storage companies for the storage of personal property) or temporary construction dumpsters will be permitted under the following conditions:
- The temporary storage unit and/or dumpster will be allowed with the community for seven (7) days.
  - Temporary storage units and temporary dumpsters may only be placed in a resident's driveway. They are not allowed on the street. Only one storage unit and one dumpster per home will be permitted.
  - Homeowner is responsible for the cost and repair of any damage caused by the placement, storage and/or removal of such a unit to any common area property and areas, which includes parking lots and/or homeowner property.
  - Homeowner is responsible for providing prior written notice to the Board of Directors via the Management Company by supplying the dates of the use of the storage unit or dumpster.
  - The length of time needed for the portable storage unit and dumpster may be extended through communication with the management company. Additional time may be granted for extenuating circumstances. The Board of Director reserves the right to grant additional time as determined on a case-by-case basis.
- 4.1.5 **WATER BARRELS:** Barrels for the use of rainwater collections are permitted but must be placed so as to not be visible from the front of the house.

### **4.2 HOLIDAY DECORATIONS**

- 4.2.1 **HOLIDAY DECORATIONS:** All holiday decorations must be taken down within 20 days after the holiday.

APPENDIX A

**ILLUSTRATIONS**

The illustrations on the following pages are referenced to the Design Standards by paragraph number. Please refer to the designated paragraph number (also the illustration number) for the paragraph containing requirements relating to the specific illustration.

List of Illustrations

ILLUSTRATION 2.2a - DEFINITION OF YARDS.....A1

ILLUSTRATION 2.2b - DEFINITION OF YARDS - CORNER LOT .....A2

ILLUSTRATION 2.5.1 - REQUIRED MAILBOX DESIGN.....A3

ILLUSTRATION 2.9.2 - STANDARD YARD FENCE STYLES .....A4

ILLUSTRATION 2.9.3 - STANDARD PRIVACY FENCE STYLES .....A5

APPENDIX B

**NEIGHBORHOOD ADDENDUM SHEETS**

APPENDIX C

**SAMPLE APPLICATION FORM**

CONTAINS: ARC Home Improvement Application

APPENDIX A

**ILLUSTRATIONS**

The illustrations on the following pages are referenced to the Design Standards by paragraph number. Please refer to the designated paragraph number (also the illustration number) for the paragraph containing requirements relating to the specific illustration.

List of Illustrations

ILLUSTRATION 2.2a - DEFINITION OF YARDS .....A1

ILLUSTRATION 2.2b - DEFINITION OF YARDS - CORNER LOT .....A2

ILLUSTRATION 2.5.1 - REQUIRED MAILBOX DESIGN .....A3

ILLUSTRATION 2.9.2 - STANDARD YARD FENCE STYLES .....A4

ILLUSTRATION 2.9.3 - STANDARD PRIVACY FENCE STYLES .....A5

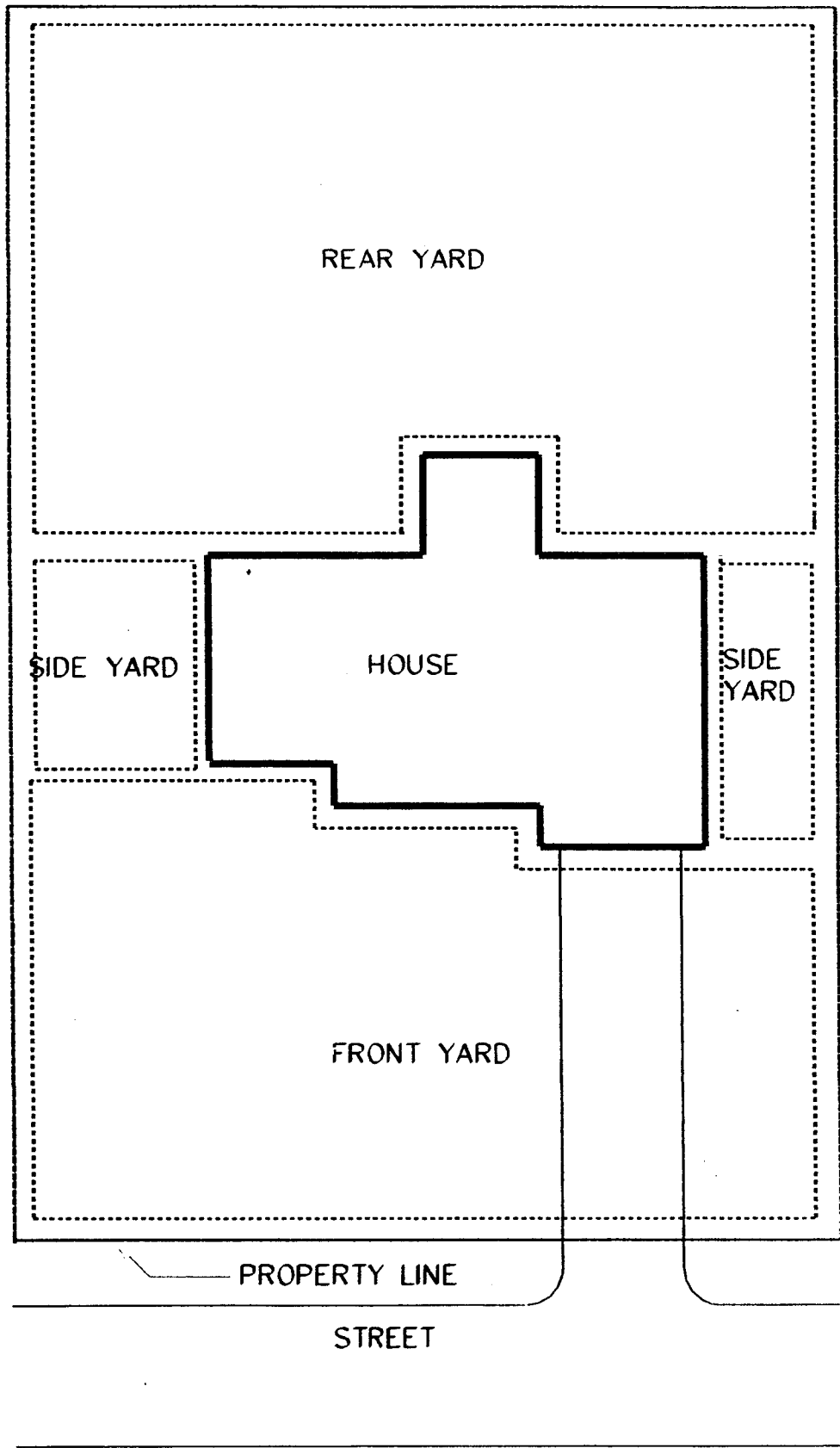

Illustration 2.2a - Definition of Yards

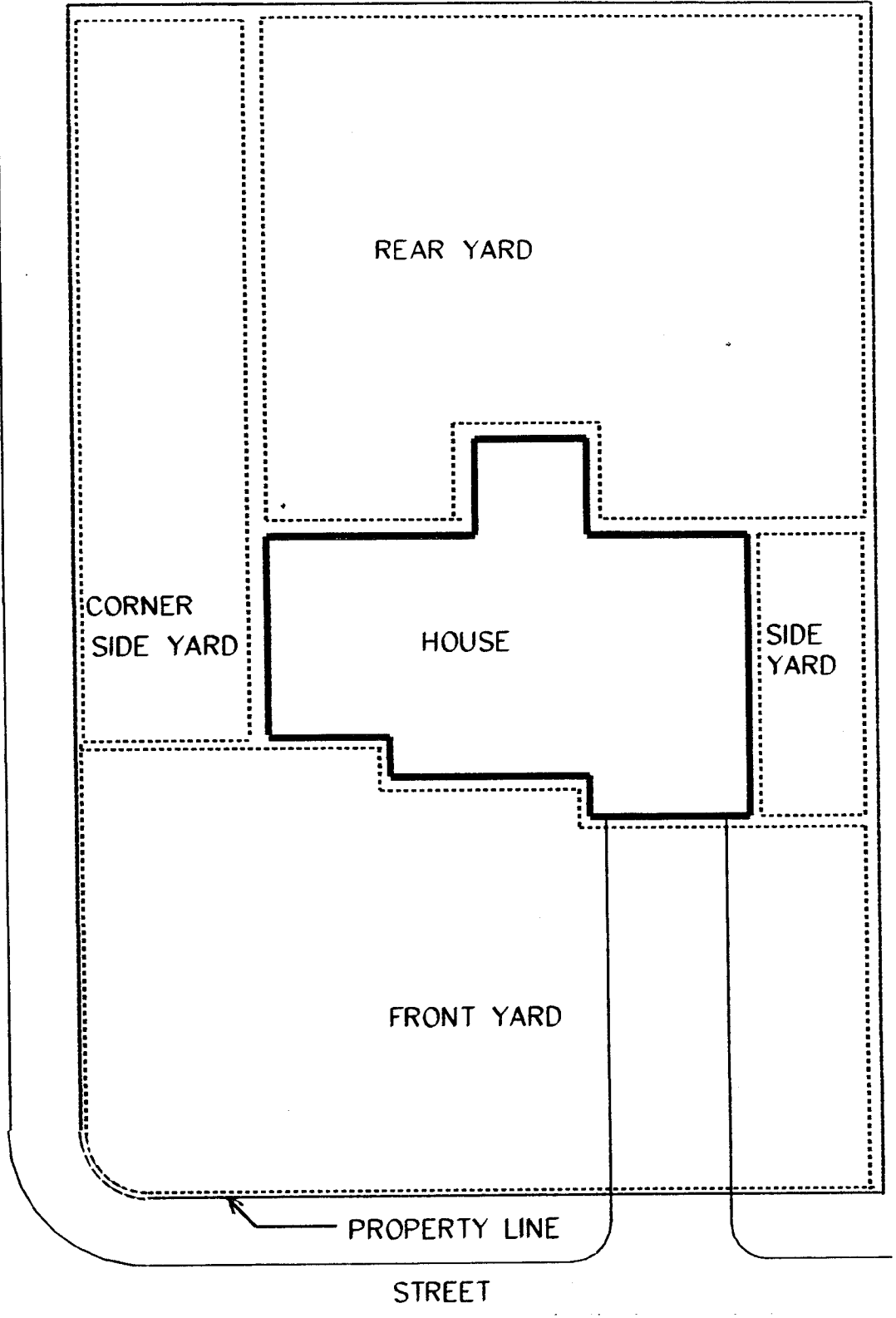
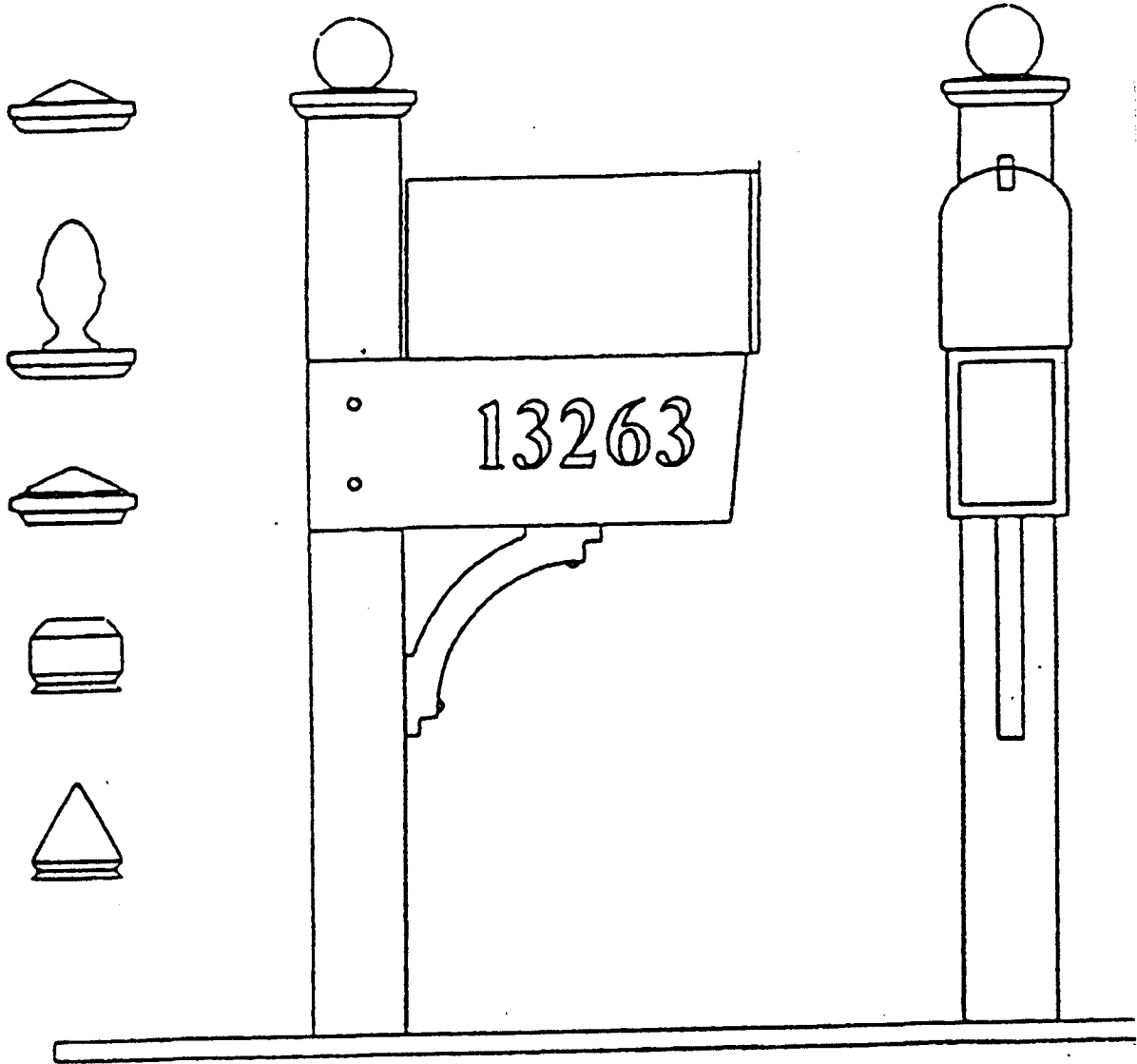
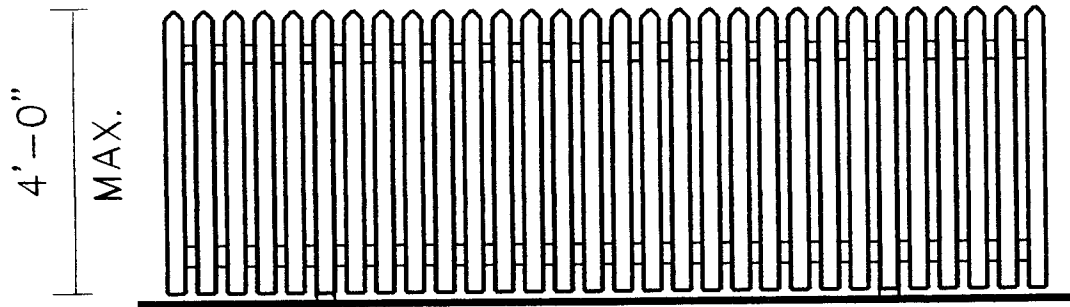

Illustration 2.2b - Definition of Yards - Corner Lot



*Illustration 2.5.1 - Required Mailbox Design*





TYPICAL PICKET FENCE

NO LONGER AN APPROVED OPTION FOR FENCE

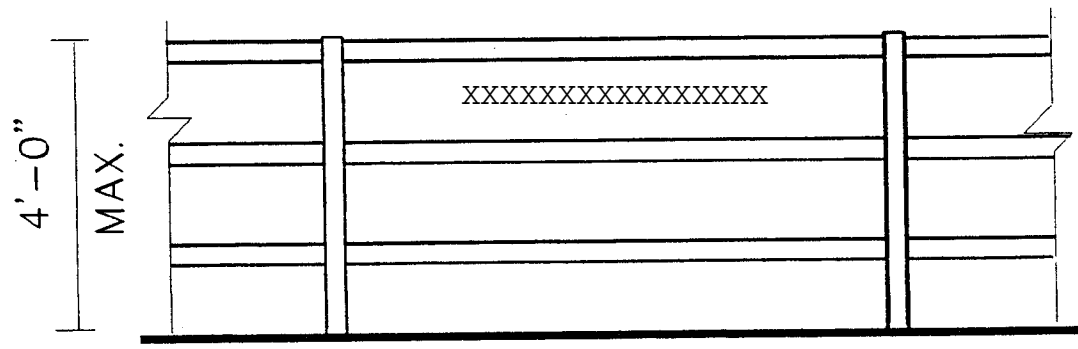

TYPICAL BOARD RAIL FENCE

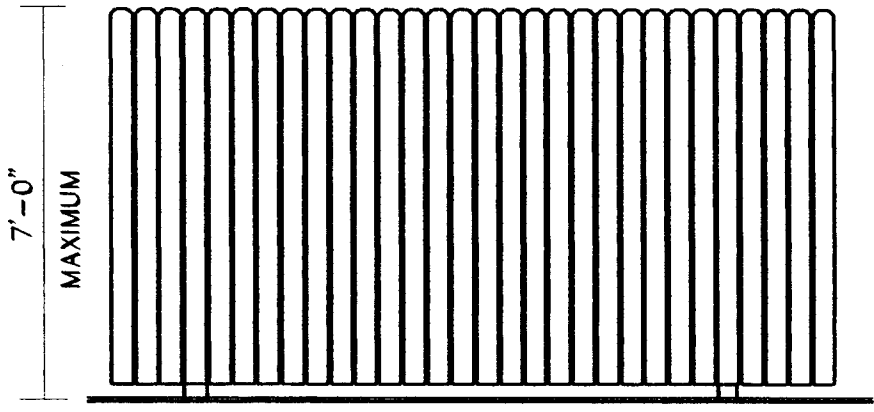

SOLID BOARD PRIVACY FENCE

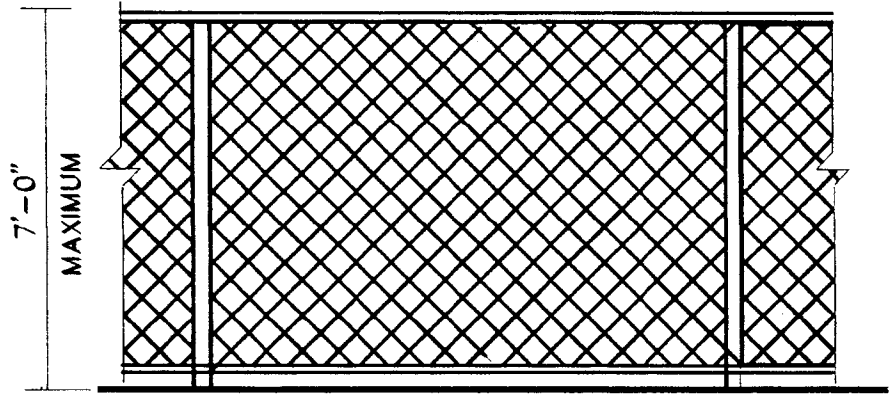

LATTICE PRIVACY FENCE

APPENDIX B  
NEIGHBORHOOD ADDENDUM SHEETS

---

# BIGGIN POND

---

POST LAMP STYLE  
P5432-10

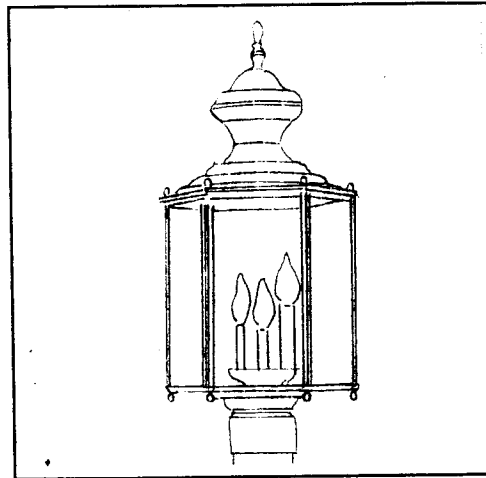

## HOUSE REQUIREMENTS

- MINIMUM FINISHED FLOOR AREA: ..... 2850 SF
- MAXIMUM FINISHED FLOOR AREA: ..... N/A
- GARAGE STANDARDS: ..... TWO-CAR ATTACHED
- FOUNDATION REQUIREMENTS: ..... DECORATIVE LOUVERED VENTS ON STREET  
FACING ELEVATIONS
- MINIMUM ROOFING REQUIREMENTS: ..... 25 YEAR DIMENSIONAL ASPHALT SHINGLE

## YARD REQUIREMENTS

- MINIMUM SHRUBBERY ALLOWANCE: ..... \$750.00
- SOD AND IRRIGATION REQUIREMENT: ..... OPTIONAL

---

# GRAVITY HILL

---

POST LAMP STYLE  
P5427-10

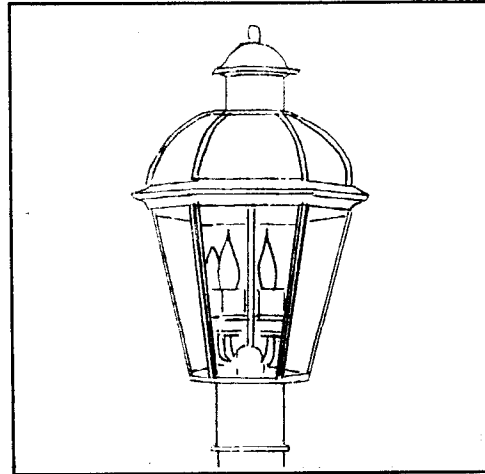

## HOUSE REQUIREMENTS

- MINIMUM FINISHED FLOOR AREA (TWO STORY HOUSES): ..... 2750 SF
- MAXIMUM FINISHED FLOOR AREA (ONE STORY HOUSES): ..... 2400 SF
- GARAGE STANDARDS: ..... TWO-CAR, SIDE OR REAR ENTRY ONLY
- FOUNDATION REQUIREMENTS: ..... BRICK FOUNDATION, DECORATIVE LOUVERED  
VENTS ON STREET FACING ELEVATIONS
- MINIMUM ROOFING REQUIREMENTS: ..... 25 YEAR DIMENSIONAL ASPHALT SHINGLES

## YARD REQUIREMENTS

- MINIMUM SHRUBBERY ALLOWANCE: ..... \$1,000.00
- SOD AND IRRIGATION REQUIREMENT: ..... ALL FRONT AND SIDE YARDS

---

# HAWKINS WOOD

---

**POST LAMP STYLE  
K-9445**

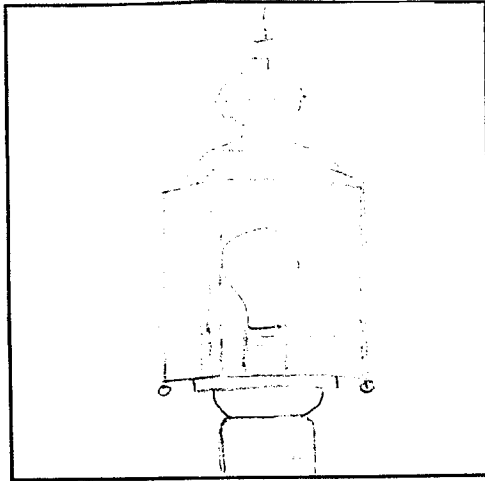

**HOUSE REQUIREMENTS**

- MINIMUM FINISHED FLOOR AREA:** ..... 2500 SF
- MAXIMUM FINISHED FLOOR AREA:** ..... N/A
- GARAGE STANDARDS:** ..... N/A
- FOUNDATION REQUIREMENTS:** ..... **BRICK FOUNDATION STANDARD**
- MINIMUM ROOFING REQUIREMENTS:** ..... 20 YEAR STANDARD ASPHALT SHINGLE

**YARD REQUIREMENTS**

- MINIMUM SHRUBBERY ALLOWANCE:** ..... \$500.00
- SOD AND IRRIGATION REQUIREMENT:** ..... **OPTIONAL**

---

**The Grove**

The standards illustrated on this sheet are in addition to the minimum written design standards for The Grove, and are requirements that apply only to all homes in this neighborhood.

**Neighborhood Addendum**

Issue Date 6/99 (supercedes all previous issues)

**APPENDIX C**  
**SAMPLE APPLICATION FORM**

CONTAINS:

ARC Home Improvement Application

# THE GROVE

Community Group, Inc., AAMC  
 An Associa Company  
 3901 Westerre Parkway, Suite 100,  
 Richmond, VA 23233  
 (804) 270-1800 (Office)  
 Email to: email@communitygroup.com

## Modification Committee Home Improvement Application

**Property Owner:** \_\_\_\_\_

**Mailing Address:** \_\_\_\_\_  
 \_\_\_\_\_

**Phone #:** Home \_\_\_\_\_ Cell \_\_\_\_\_ Email \_\_\_\_\_

CHECK BOX	TYPE REQUEST	REQUIRED ATTACHMENTS
	<b>HOUSE ADDITION</b>	1) Plans elevations of addition showing connection and architectural relationship to house. Identify exterior materials 2) Site pan showing addition location, main house, distances to property lines.
	<b>EXTERIOR MODIFICATION</b> (Changes in materials, ornamentation etc.)	1) Scale drawing of modification, or photograph, or catalogue information on product. Show where change will be made on house.
	<b>ACCESSORY BUILDING</b> (tool shed, workshop, garage, pool house, gazebo, etc.)	1) Plans and elevations of structure showing all architectural details. Identify exterior materials. 2) Site plan showing location relationship to main house, distances to property lines. 3) Project location is to be staked-out for site review by committee member.
	<b>PROPERTY IMPROVEMENT</b> (swimming pool, spa, patio or other pavement, etc.)	1) Plans of improvement. Identify exterior materials. 2) Catalogue information of purchased product (ex. spa.) 3) Site plan showing location relationship to main house, distances to property lines.
	<b>FENCE / WALL</b>	1) Elevation drawing of type of fence or wall, height, materials. 2) Site plan (Plat) showing location and extent.
	<b>COLOR CHANGE</b>	1) Paint chips or samples of finished product.
	<b>LANDSCAPING</b>	1) Landscape plan with new materials and sizes identified.

**Brief description of changes being requested:**

\_\_\_\_\_  
 \_\_\_\_\_  
 \_\_\_\_\_  
 \_\_\_\_\_  
 \_\_\_\_\_

### Office Use Only

**Application:** ( ) Approved as submitted ( ) Not Approved  
 ( ) Approved with limiting conditions (see memo) ( ) Preliminary Review

**Signature:** \_\_\_\_\_ **Date:** \_\_\_\_\_  
 Modification Committee

Approval is limited to design criteria established by the Modification Committee and should not be interpreted as approval of any variation from restrictions or conditions imposed on the property owner by Chesterfield County. Approval of siting does not necessarily imply compliance with County zoning requirements. All applicable County and State building codes must be strictly adhered to.